

LUXMAN

INTEGRATED AMPLIFIER
L-509Z



Introducing our next-level “single-chassis separates” concept, pursuing the ideal with a new, all-in-one flagship amplifier. Taking our Z-Series integrated amplifiers to a performance peak.

As the premium model for the new Z-Series generation,

the L-509Z has evolved beyond the concept of a traditional integrated amplifier.

Both the preamplifier and power amplifier sections simultaneously use our new generation amplification feedback engine “LIFES” for the first time.

The volume control is supported by our new “LECUA-EX” attenuator system that suppresses sound quality deterioration and realizes a more precise feel of operation.

The “single-chassis separates” concept, which aims for the ultimate in integrated amplifiers, now achieves unprecedented performance.

Pursuing the ideals of audio enthusiasm, we are combining our passion for music with improved technology.

The L-509Z, a new pinnacle of Luxman integrated amplifier design.



Our latest amplification feedback engine literally brings music to life with LIFES* Version 1.0

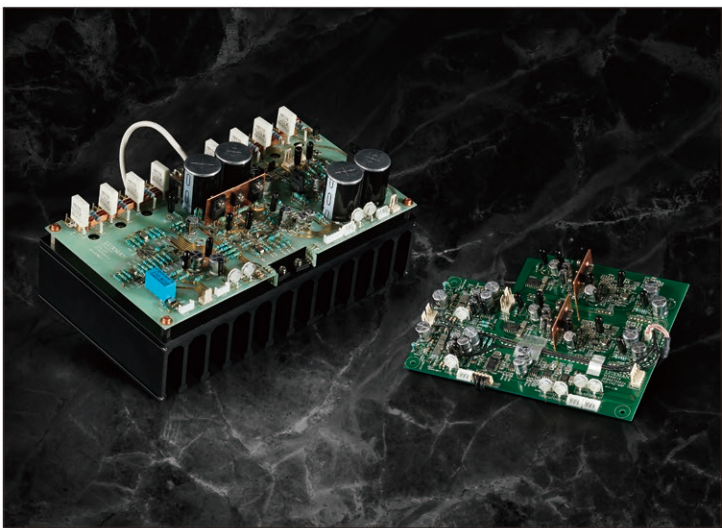

By feeding back only the distorted components generated in the audio signal's journey to the final amp stage, LUXMAN's proprietary “ODNF” amplification circuitry achieves excellent static characteristics and natural sound quality as if it were a “non-feedback” system. During the development of the M-10X flagship stereo power amplifier launched in 2021, technical concepts explored there were retained and the circuit configuration, which had become very complex over years of improvements has been completely redesigned to realize “LIFES” exquisite, high-fidelity sound and defines an amplification feedback engine blueprint for our next generation of components. The L-509Z is equipped with independent LIFES modules operating simultaneously in each of its fully discrete pre and power sections. The L-509Z is a pre-main amplifier that is worthy of the “single-chassis separates” concept that incorporates quality separate units into a single, elegant chassis and has achieved an elevated level of musicality and unprecedented detail in comparison to other amplification circuits. The output section utilizes three stage Darlington bipolar transistors in quadruple-paralleled push-pull configuration to achieve outstanding output power and near perfect power linearity performance comparable to a standalone power amplifier, developing 120W+120W at 8 ohms and 220W+220W at 4 ohms. The result is spectacular sound quality with an abundance of energy.

*ODNF stands for “Only Distortion Negative Feedback”

*LIFES stands for “Luxman Integrated Feedback Engine System”.

Equipped with supreme quality audio technologies and new functionality suitable for a flagship model

Highly regulated power supply



The L-509Z is equipped with LUXMAN's traditional, highly stable power supply circuitry, featuring a bespoke, highly regulated 600VA EI transformer and newly developed large-capacity filter capacitors (10,000µF x 8).

High-quality hairline finish top panel



The top panel is made of ultra-thick aluminum with an exquisite hairline finish. Large ventilation holes are carefully machined one by one to ensure efficient heat dissipation. Supporting the unit are four large insulator feet made from cast iron, their density gradient protecting the main chassis from unwanted external vibrations.

High-quality phono EQ

The built-in high-quality phono equalizer circuit, which supports both MM and MC cartridges, features a new two-step gain switch to select between high and low MC settings to accommodate a wider range of MC cartridges, enriching quality vinyl playback in terms of both operation and sound quality. And a Mute-Button is now featured on the front panel.

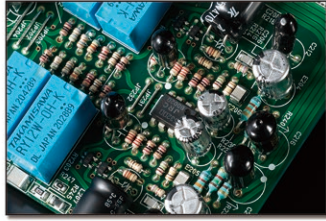

Large needle-movement VU level meter and 7-segment LED

Needle-movement type analog VU meters are traditional design statement, proudly characterizing LUXMAN's solid state integrated amplifiers. The L-509Z is equipped with two large meters, brightly back-lit by LEDs, with sensitive response characteristics. The newly included 7-segment LED display in between the left and right level meters displays the current attenuation amount and is easily visible from the listening position.



3-band tone control



In addition to BASS and TREBLE, a new MIDDLE control effective in the vocal and lead instrument frequencies bandwidth has been included. LR balance, line straight, loudness, and other functions are also conveniently at your fingertips.

Headphones outputs with ground isolation



In addition to the $\phi 6.3\text{mm}$ standard terminal, a $\phi 4.4\text{mm}$ terminal with independent left and right grounding has been added for pleasurable headphone enjoyment. Using balanced cable equipped headphones improves L-R separation and localization, surrounding the listener with gorgeous three-dimensional sound.

Original technology, special attention

Peel-coat circuit boards are used for the main audio signal path, eliminating the negative effects of the coating film that can adversely affect sound quality. Unique attention has been paid to every detail, such as the beeline construction, which configures circuits to take the shortest route possible, and a non-angled wiring pattern for smooth signal transmission.

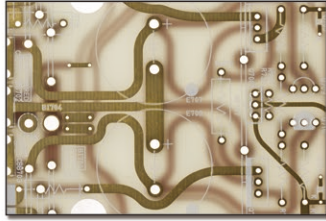

High quality input/output terminals

Original high rigidity RCA terminals are used for LINE-1 and 2. Separate inputs and outputs for system expansion are provided with two pre-outputs. Two large speaker output terminals with independent on/off switching allow for bi-wire connectivity.



Low-impedance transmission



Large, low resistance speaker relays are connected in parallel to transmit the driving force from the substantial power supply and output circuitry. Internal, 3.5mm^2 ultra-thick cable is directly connected to the speaker terminals to ensure low impedance transmission, achieving a damping factor of 330 (current injection method).

Ergonomic aluminum remote control



The substantial, ergonomic aluminum alloy remote control can also operate compatible LUXMAN CD players released after 1996.

Electronically controlled attenuator LECUA-EX* incorporating an elaborate rotation mechanism



A tactile, satisfying volume control function is essential for audio amplifiers. To feed a fixed gain power amplifier with a musical signal at a level suitable for listening, precise control is required to smoothly attenuate the voltage while maintaining the quality of the input source. LECUA, developed by LUXMAN, is an electronically controlled attenuator system that switches through a series of high-quality, fixed value resistors for each channel independently. These are neatly arranged on the sub-assembly according to the position of the volume control knob. Since the release of the C-1000f control amplifier in 2006 to commemorate LUXMAN's 80th anniversary, "LECUA1000", which similarly integrates into the amplification circuitry, has been used in many LUXMAN products as a volume control system that minimizes the effects of external vibrations and changes in sound quality across the operating range of the volume control and is also resistant to deterioration over time. The L-509Z combines a highly precise rotary encoder with a newly developed weighted rotation mechanism to create the "LECUA-EX", which offers even greater reliability and a natural, high-quality operational feel. 88 fine steps from 0 to 87dB and an acceleration setting for the speed at which the volume knob is rotated and a long-press setting for the remote control allow for comfortable and thorough volume control action with minimal degradation in sound quality.

*LECUA-EX stands for Luxman Electronically Controlled Ultimate Attenuator - Excellent eXperience

L-509Z INTEGRATED AMPLIFIER

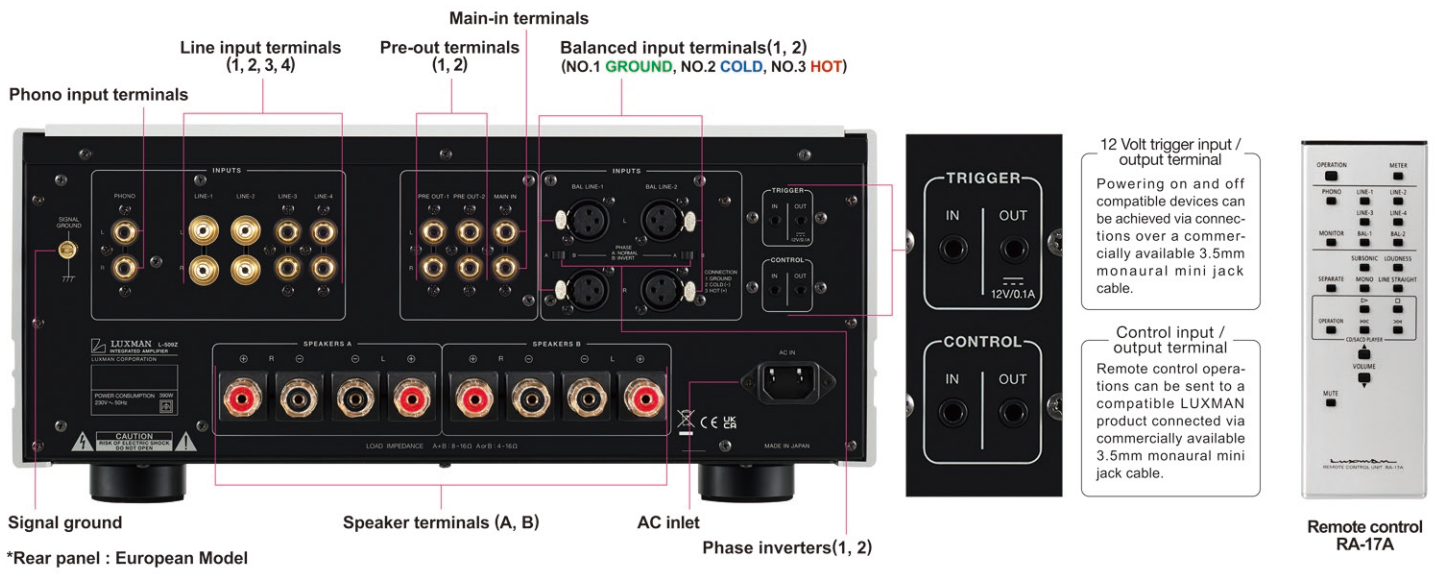
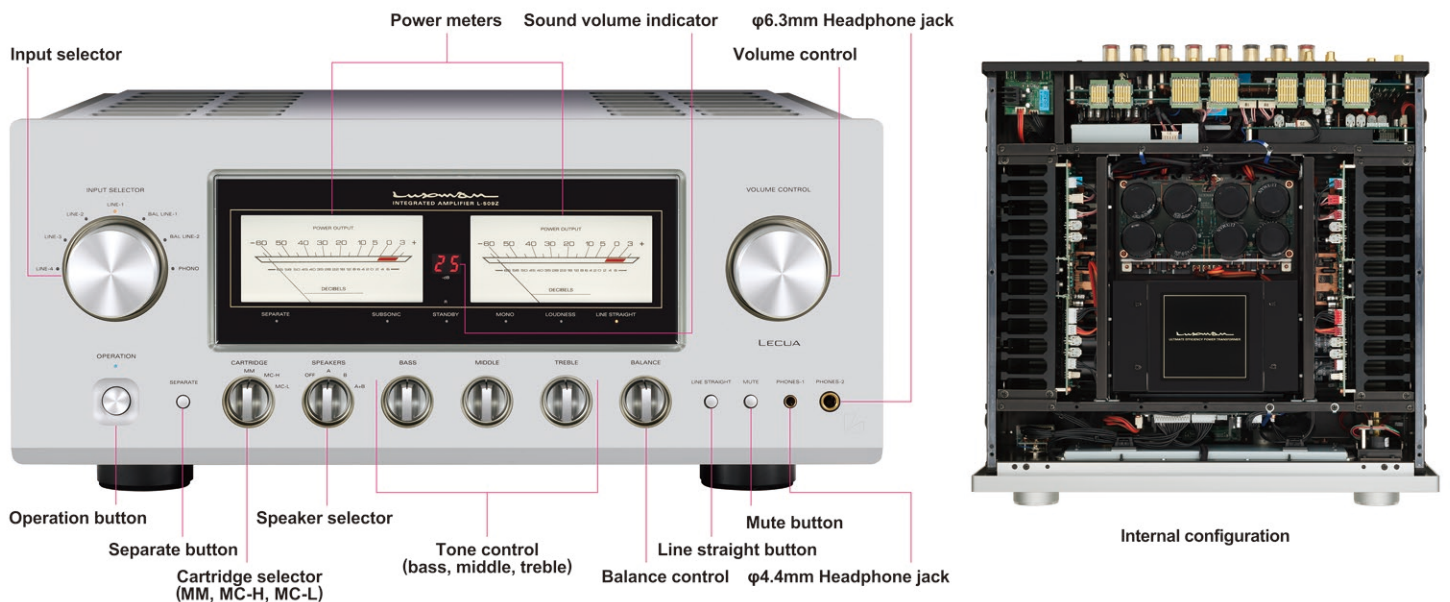

SPECIFICATIONS

Rated output	120W + 120W (8Ω) 220W + 220W (4Ω)
Input sensitivity/ input impedance	PHONO (MM) : 2.5mV/47kΩ PHONO (MC-H) : 0.3mV/100Ω PHONO (MC-L) : 0.1mV/40Ω LINE : 180mV/47kΩ BAL.LINE : 180mV/79kΩ MAIN IN : 1.1V/47kΩ
Output voltage	PRE OUT : 1V
Frequency response	PHONO : 20Hz to 20kHz (±0.5dB) LINE : 20Hz to 100kHz (within -3dB)
Total harmonic distortion	0.007% or less (8Ω, 1kHz) 0.03% or less (8Ω, 20Hz to 20kHz)
S/N ratio (IHF-A)	PHONO (MM) : 87dB or more PHONO (MC-H) : 70dB or more PHONO (MC-L) : 62dB or more LINE : 106dB or more
Volume adjustment	LECUA-EX
Amplification feedback circuit	LIFES 1.0
Output configuration	Bipolar 4-parallel push-pull
Damping factor	330

Max. amount of tone control	BASS: ±8dB at 100Hz TREBLE: ±8dB at 760Hz TREBLE: ±8dB at 10kHz
Power supply	230V~(50Hz) / 115V~(60Hz)
Power consumption	390W 150W (under no signal), 0.5W (at standby)
External dimensions	440(W) x 193(H) x 463(D) mm front side knob of 20mm and rear side terminal of 37mm included in depth
Net weight	29.4kg (main unit)
Accessories	Remote control (RA-17A) Power cable
Speaker terminal Supported Y-lug terminal dimension	Width of part a: 16mm or less Width of part b: 7mm or more 

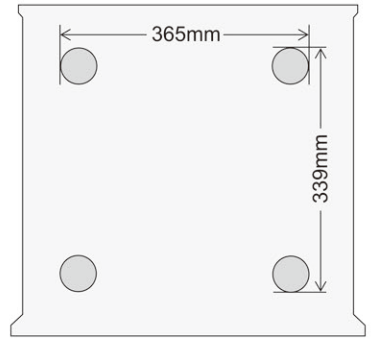

Insulator position / dimensions

* Slide the phase selector switch to the INVERT position to make the balanced input terminals pin No 2 to change to HOT, and No. 3 to COLD.

* Meter display lighting, monaural, subsonic, and loudness can be switched with the remote control.

* Specifications and appearance are subject to change without notice. * The products listed in this catalog do not include line cables. Please purchase cables separately.

LUXMAN

LUXMAN CORPORATION, 1-3-1 Shinyokohama, Kouhoku-ku, Yokohama-shi, Kanagawa 222-0033, Japan
Tel: +81-45-470-6980 Fax: +81-45-470-6997 www.luxman.com

LUXMAN reserves the right to alter the design and specifications without notice.
All rights reserved LUXMAN CORPORATION

Safety Cautions

To ensure correct use of this product, read the "Owner's Manual" prior to use. Failure to follow all safeguards can result in fire, electric shock, or other accidents.